

# Surface Mount LED Indicator

## Technical Data

**HSMD-TX00**  
**HSME-TX00**  
**HSMG-TX00**  
**HSMH-TX00**  
**HSMS-TX00**  
**HSMY-TX00**

### Features

- **Compatible with Automatic Placement Equipment**
- **Compatible with Infrared and Vapor Phase Reflow Solder Processes**
- **Packaged in 12 mm or 8 mm tape on 7" or 13" Diameter Reels**
- **EIA Standard Package**
- **Low Package Profile**
- **Nondiffused Package Excellent for Backlighting and Coupling to Light Pipes**

### Description

These solid state surface mount indicators are designed with a flat top and sides to be easily handled by automatic placement equipment. A glue pad is provided for adhesive mounting processes. They are compatible with convective IR and vapor phase reflow soldering and conductive epoxy attachment processes.

The package size and configuration conform to the EIA-535 BAAC standard specification for case size 3528 tantalum capacitors. The folded leads

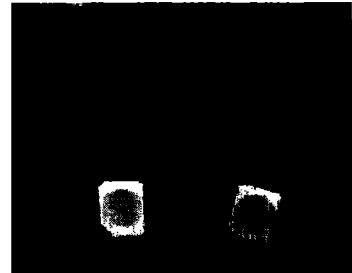

permit dense placement and provide an external solder joint for ease of inspection.

These devices are nondiffused, providing high intensity for applications such as backlighting, light pipe illumination, and front panel indication.

### Device Selection Guide

DH AS AlGaAs Red HSMH-	High Efficiency Red HSMS-	Orange HSMD-	Yellow HSMY-	High Performance Green HSMG-	Emerald Green HSME-	Description
T400	T400	T400	T400	T400	T400	12 mm Tape, 7" Reel, 2000 Devices
T500	T500	T500	T500	T500	T500	12 mm Tape, 13" Reel, 8000 Devices
T600	T600	T600	T600	T600	T600	8 mm Tape, 7" Reel, 2000 Devices
T700	T700	T700	T700	T700	T700	8 mm Tape, 13" Reel, 8000 Devices



## Package Dimensions

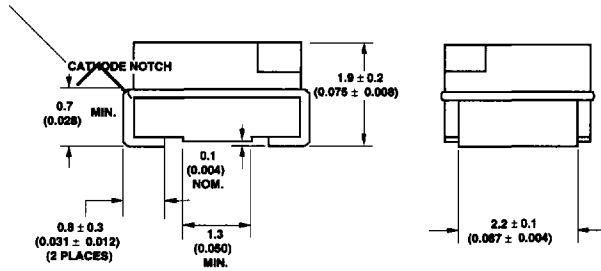
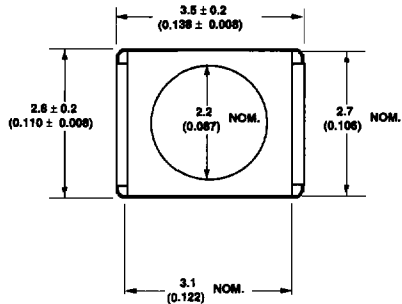

## Tape and Reel Specifications

Hewlett Packard surface mount LEDs are packaged tape and reel in accordance with EIA-481A, *Taping of Surface Mount*

*Components for Automatic Placement.* This packaging system is compatible with taped automatic pick and place systems. Each reel is sealed in a

vapor barrier bag for added protection. Bulk packaging in vapor barrier bags is available upon special request.

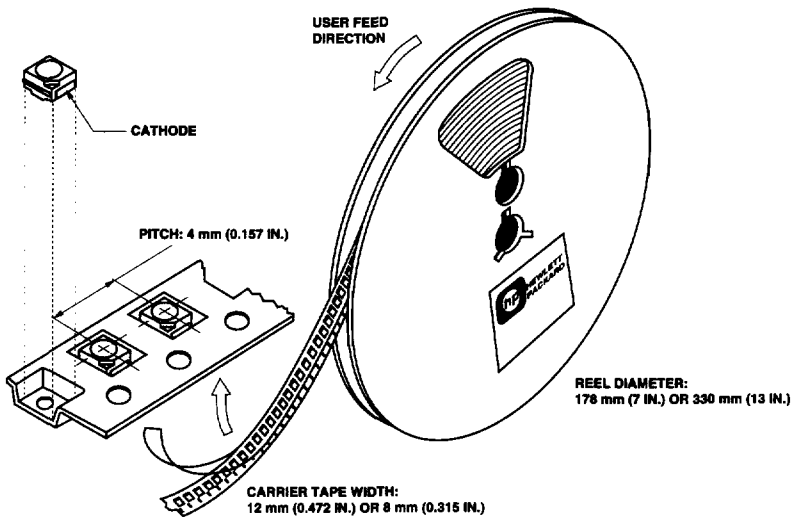

### Absolute Maximum Ratings at $T_A = 25^\circ\text{C}$

Parameter	DH AS AlGaAs Red	High Efficiency Red	Orange	Yellow	High Perf. Green	Emerald Green	Units
DC Forward Current <sup>[1]</sup>	30	30	30	30	30	30	mA
Peak Forward Current <sup>[2]</sup>	300	90	90	60	90	90	mA
Average Forward Current <sup>[2]</sup>	20	25	25	20	25	25	mA
LED Junction Temperature	95						$^\circ\text{C}$
Transient Forward Current <sup>[3]</sup> (10 $\mu\text{s}$ Pulse)	500						mA
Reverse Voltage ( $I_R = 100\text{ mA}$ )	5						V
Operating Temperature Range	-40 to +85					-20 to +85	$^\circ\text{C}$
Storage Temperature Range	-40 to +85						$^\circ\text{C}$
Reflow Soldering Temperature Convective IR Vapor Phase	235 $^\circ\text{C}$ Peak, above 185 $^\circ\text{C}$ for 90 seconds. 215 $^\circ\text{C}$ for 3 minutes.						

**Notes:**

1. Derate dc current linearly from 50 $^\circ\text{C}$ : For AlGaAs red, high efficiency red, and green devices at 0.67 mA/ $^\circ\text{C}$ . For yellow devices at 0.44 mA/ $^\circ\text{C}$ .
2. Refer to Figure 5 showing Maximum Tolerable Peak Current vs. Pulse duration to establish pulsed operating conditions.
3. The transient peak current is the maximum non-recurring peak current the device can withstand without damaging the LED die and wire bond. The device should not be operated at peak currents above the Absolute Maximum Peak Forward Current.

## Electrical/Optical Characteristics at $T_A = 25^\circ\text{C}$

### DH AS AlGaAs Red HSMH-TX00

Parameter	Symbol	Min.	Typ.	Max.	Units	Test Conditions
Luminous Intensity	$I_v$	9.0	17.0		mcd	$I_F = 10 \text{ mA}$
Forward Voltage	$V_F$		1.8	2.2	V	$I_F = 10 \text{ mA}$
Reverse Breakdown Voltage	$V_R$	5.0	15.0		V	$I_R = 100 \mu\text{A}$
Included Angle Between Half Intensity Points <sup>[1]</sup>	$2\theta_{1/2}$		120		deg.	
Peak Wavelength	$\lambda_{\text{PEAK}}$		645		nm	
Dominant Wavelength <sup>[2]</sup>	$\lambda_d$		637		nm	
Spectral Line Half Width	$\Delta\lambda_{1/2}$		20		nm	
Speed of Response	$\tau_s$		30		ns	Time Constant, $e^{-t/\tau_s}$
Capacitance	C		30		pF	$V_F = 0, f = 1 \text{ MHz}$
Thermal Resistance	$R\theta_{\text{J-pin}}$		180		$^\circ\text{C/W}$	Junction-to-Cathode
Luminous Efficacy <sup>[3]</sup>	$\eta_v$		80		lm/W	

### High Efficiency Red HSMS-TX00

Parameter	Symbol	Min.	Typ.	Max.	Units	Test Conditions
Luminous Intensity	$I_v$	2.0	6.0		mcd	$I_F = 10 \text{ mA}$
Forward Voltage	$V_F$		1.9	2.5	V	$I_F = 10 \text{ mA}$
Reverse Breakdown Voltage	$V_R$	5.0	30.0		V	$I_R = 100 \mu\text{A}$
Included Angle Between Half Intensity Points <sup>[1]</sup>	$2\theta_{1/2}$		120		deg.	
Peak Wavelength	$\lambda_{\text{PEAK}}$		635		nm	
Dominant Wavelength <sup>[2]</sup>	$\lambda_d$		626		nm	
Spectral Line Half Width	$\Delta\lambda_{1/2}$		40		nm	
Speed of Response	$\tau_s$		90		ns	Time Constant, $e^{-t/\tau_s}$
Capacitance	C		11		pF	$V_F = 0, f = 1 \text{ MHz}$
Thermal Resistance	$R\theta_{\text{J-pin}}$		160		$^\circ\text{C/W}$	Junction-to-Cathode
Luminous Efficacy <sup>[3]</sup>	$\eta_v$		145		lm/W	

#### Notes:

- $\theta_{1/2}$  is the off-axis angle where the luminous intensity is half the on-axis value.
- The dominant wavelength,  $\lambda_d$ , is derived from the CIE Chromaticity Diagram and represents the color of the device.
- The radiant intensity,  $I_e$ , in watts per steradian, may be found from the equation  $I_e = I_v / \eta_v$ , where  $I_v$  is the luminous intensity in candelas and  $\eta_v$  is luminous efficacy in lumens/watt.

### Orange HSMD-TX00

Parameter	Symbol	Min.	Typ.	Max.	Units	Test Conditions
Luminous Intensity	$I_v$	1.5	5.0		mcd	$I_F = 10 \text{ mA}$
Forward Voltage	$V_F$		1.9	2.5	V	$I_F = 10 \text{ mA}$
Reverse Breakdown Voltage	$V_R$	5.0	30.0		V	$I_R = 100 \mu\text{A}$
Included Angle Between Half Intensity Points <sup>(1)</sup>	$2\theta^{1/2}$		120		deg.	
Peak Wavelength	$\lambda_{PEAK}$		600		nm	
Dominant Wavelength <sup>(2)</sup>	$\lambda_d$		602		nm	
Spectral Line Half Width	$\Delta\lambda_{1/2}$		40		nm	
Speed of Response	$\tau_s$		260		ns	Time Constant, $e^{-t/\tau_s}$
Capacitance	C		4		pF	$V_F = 0, f = 1 \text{ MHz}$
Thermal Resistance	$R\theta_{J-pin}$		160		°C/W	Junction-to-Cathode
Luminous Efficacy <sup>(3)</sup>	$\eta_v$		380		lm/W	

### Yellow HSMY-TX00

Parameter	Symbol	Min.	Typ.	Max.	Units	Test Conditions
Luminous Intensity	$I_v$	2.0	5.0		mcd	$I_F = 10 \text{ mA}$
Forward Voltage	$V_F$		2.0	2.5	V	$I_F = 10 \text{ mA}$
Reverse Breakdown Voltage	$V_R$	5.0	50.0		V	$I_R = 100 \mu\text{A}$
Included Angle Between Half Intensity Points <sup>(1)</sup>	$2\theta^{1/2}$		120		deg.	
Peak Wavelength	$\lambda_{PEAK}$		583		nm	
Dominant Wavelength <sup>(2)</sup>	$\lambda_d$		585		nm	
Spectral Line Half Width	$\Delta\lambda_{1/2}$		36		nm	
Speed of Response	$\tau_s$		90		ns	Time Constant, $e^{-t/\tau_s}$
Capacitance	C		15		pF	$V_F = 0, f = 1 \text{ MHz}$
Thermal Resistance	$R\theta_{J-pin}$		160		°C/W	Junction-to-Cathode
Luminous Efficacy <sup>(3)</sup>	$\eta_v$		500		lm/W	

#### Notes:

- $\theta^{1/2}$  is the off-axis angle where the luminous intensity is half the on-axis value.
- The dominant wavelength,  $\lambda_d$ , is derived from the CIE Chromaticity Diagram and represents the color of the device.
- The radiant intensity,  $I_e$ , in watts per steradian, may be found from the equation  $I_e = I_v / \eta_v$ , where  $I_v$  is the luminous intensity in candelas and  $\eta_v$  is luminous efficacy in lumens/watt.

**High Performance Green HSMG-TX00**

Parameter	Symbol	Min.	Typ.	Max.	Units	Test Conditions
Luminous Intensity	$I_v$	4.0	10.0		mcd	$I_F = 10 \text{ mA}$
Forward Voltage	$V_F$		2.0	2.5	V	$I_F = 10 \text{ mA}$
Reverse Breakdown Voltage	$V_R$	5.0	50.0		V	$I_R = 100 \mu\text{A}$
Included Angle Between Half Intensity Points <sup>[1]</sup>	$2\theta_{1/2}$		120		deg.	
Peak Wavelength	$\lambda_{\text{PEAK}}$		570		nm	
Dominant Wavelength <sup>[2]</sup>	$\lambda_d$		572		nm	
Spectral Line Half Width	$\Delta\lambda_{1/2}$		28		nm	
Speed of Response	$\tau_s$		500		ns	Time Constant, $e^{-t/\tau_s}$
Capacitance	C		18		pF	$V_F = 0, f = 1 \text{ MHz}$
Thermal Resistance	$R\theta_{\text{J-pin}}$		160		°C/W	Junction-to-Cathode
Luminous Efficacy <sup>[3]</sup>	$\eta_v$		595		lm/W	

**Notes:**

- $\theta_{1/2}$  is the off-axis angle where the luminous intensity is half the on-axis value.
- The dominant wavelength,  $\lambda_d$ , is derived from the CIE Chromaticity Diagram and represents the color of the device.
- The radiant intensity,  $I_e$ , in watts per steradian, may be found from the equation  $I_e = I_v/\eta_v$ , where  $I_v$  is the luminous intensity in candelas and  $\eta_v$  is luminous efficacy in lumens/watt.

**Emerald Green HSME-TX00**

Parameter	Symbol	Min.	Typ.	Max.	Units	Test Conditions
Luminous Intensity	$I_v$	1.0	1.5		mcd	$I_F = 10 \text{ mA}$
Forward Voltage	$V_F$		2.2	2.27	V	$I_F = 10 \text{ mA}$
Reverse Breakdown Voltage	$V_R$	5.0	50.0		V	$I_R = 100 \mu\text{A}$
Included Angle Between Half Intensity Points <sup>[1]</sup>	$2\theta_{1/2}$		120		deg.	
Peak Wavelength	$\lambda_{\text{PEAK}}$		558		nm	
Dominant Wavelength <sup>[2]</sup>	$\lambda_d$		560		nm	
Spectral Line Half Width	$\Delta\lambda_{1/2}$		28		nm	
Speed of Response	$\tau_s$		500		ns	Time Constant, $e^{-t/\tau_s}$
Capacitance	C		52		pF	$V_F = 0, f = 1 \text{ MHz}$
Thermal Resistance	$R\theta_{\text{J-pin}}$		120		°C/W	Junction-to-Cathode
Luminous Efficacy <sup>[3]</sup>	$\eta_v$		680		lm/W	

**Notes:**

- $\theta_{1/2}$  is the off-axis angle where the luminous intensity is half the on-axis value.
- The dominant wavelength,  $\lambda_d$ , is derived from the CIE Chromaticity Diagram and represents the color of the device.
- The radiant intensity,  $I_e$ , in watts per steradian, may be found from the equation  $I_e = I_v/\eta_v$ , where  $I_v$  is the luminous intensity in candelas and  $\eta_v$  is luminous efficacy in lumens/watt.
- Refer to Application Note 1061 for information comparing high performance green with emerald green light output degradation.

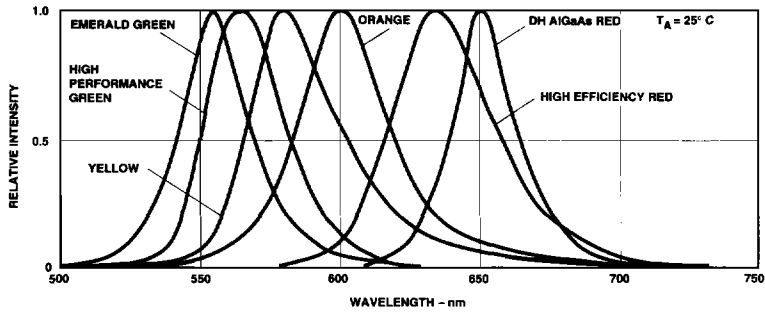

Figure 1. Relative Intensity vs. Wavelength.

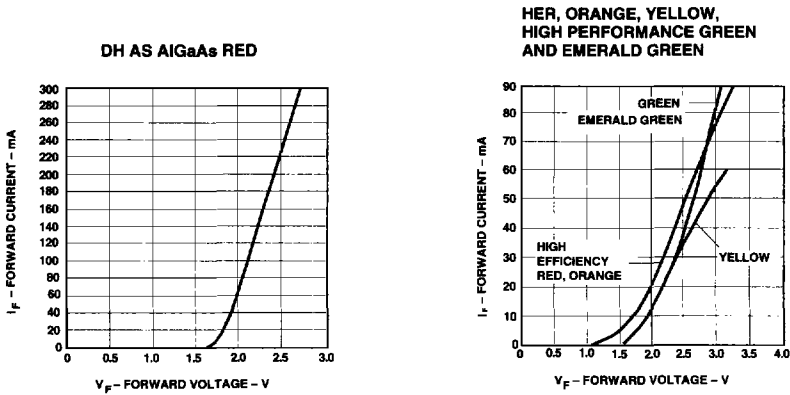

Figure 2. Forward Current vs. Forward Voltage.

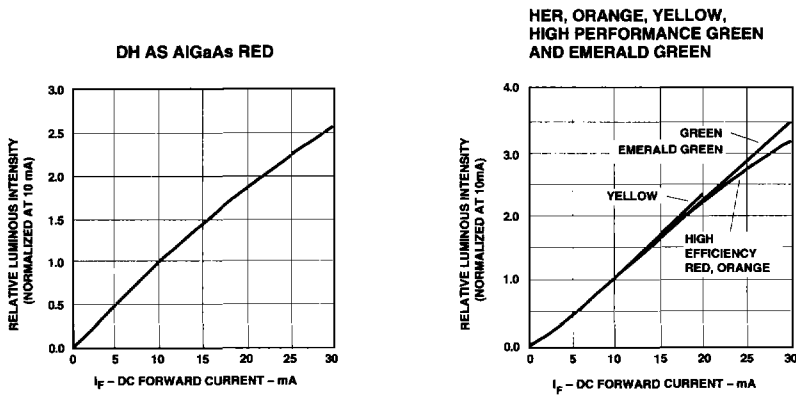

Figure 3. Relative Luminous Intensity vs. Forward Current.

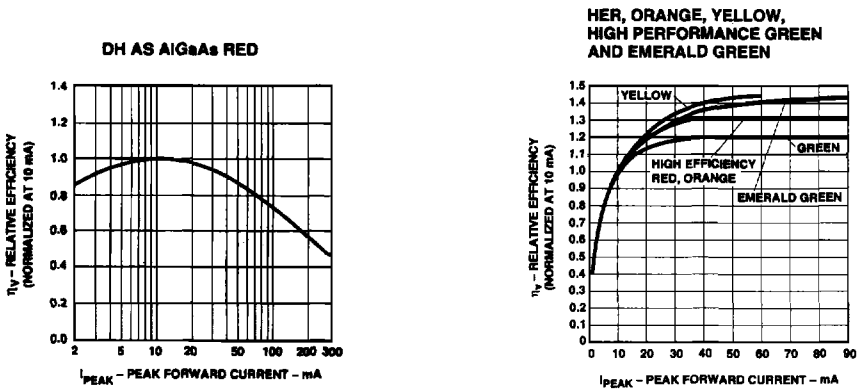

Figure 4. Relative Efficiency (Luminous Intensity per Unit Current) vs. Peak Current.

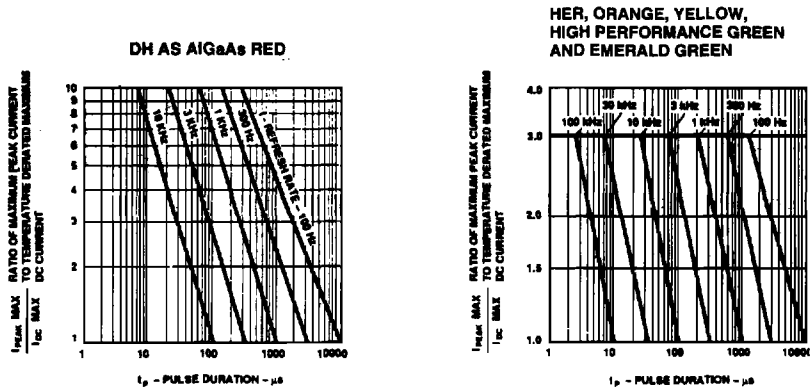

Figure 5. Maximum Tolerable Peak Current vs. Pulse Duration ( $I_{DC}$  MAX per MAX Ratings).

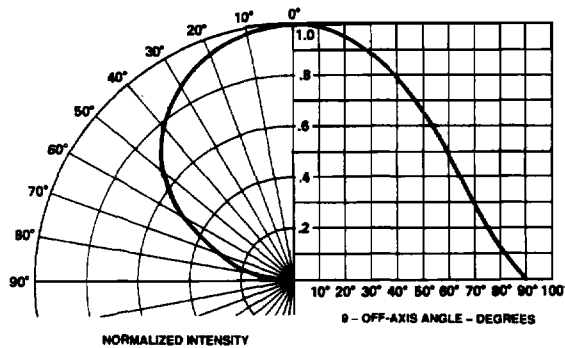

Figure 6. Relative Intensity vs. Angular Displacement.